

COM17035

GPS and GPRS GSM Modem Module

User's Manual

Hardware revision 1.1

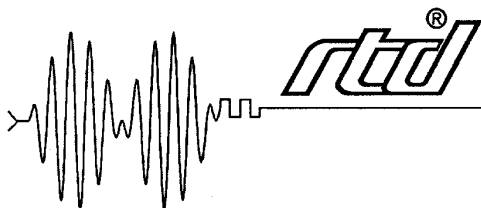

Real Time Devices, Inc.

"Accessing the Analog World"®

COM17035
GPS and GPRS GSM Modem Module
User's Manual

REAL TIME DEVICES FINLAND OY
LEPOLANTIE 14
FIN-00660 HELSINKI
FINLAND

Phone: (+358) 9 346 4538
FAX: (+358) 9 346 4539

E-Mail
sales@rtdfinland.fi
techsupport@rtdfinland.fi

Websites
<http://www.rtdfinland.fi/>
<http://www.rtdusa.com/>

WARNING

LIFE SUPPORT APPLICATIONS

This product is not designed for use in life support appliances, devices or systems where malfunctioning of these products can reasonably be expected to result in personal injury. RTD customers using or selling this product for use in these applications do so at their own risk and fully agree to indemnify RTD for any damages resulting from such improper use or sale.

SAFETY PRECAUTIONS FOR THE USER

1) AIRCRAFT SAFETY

The MC35 cellular engine used on the COM17035 can interfere with an aircraft's navigation system and its cellular network. Using your COM17035 on board aircraft is forbidden by law. Failure to comply with this prohibition may lead to temporary suspension or permanent cancellation of cellular services for the person who infringes this prohibition and/or legal action against said person.

2) ENVIRONMENTS WITH EXPLOSIVE SUBSTANCES

Users are not advised to use the COM17035 in automotive service stations. Users are reminded of the necessity to comply with restrictions regarding the use of radio devices in fuel depots, chemical plants and locations where explosives are ignited.

3) ELECTRONICS IN MEDICAL APPLICATIONS

Radio transmitters such as the COM17035 can interfere with the operation of inadequately protected medical devices. Please address all questions to a doctor or manufacturer of the medical device.

4) PRECAUTIONS IN THE EVENT OF LOSS/THEFT OF COM17035 AND SIM CARD

If your COM17035, SIM card or both go missing, notify your network operator immediately in order to avoid misuse.

Revision History

05/04/2002 HW Release 1.1, Preliminary version, released

CE Conformity of MC35 cellular engine:

- 89/336/EC (EMC Directive)
- 73/23/EC (Low voltage directive)
- 91/263/EC (telecommunications terminals directive)

Standards:

- EMC ETS 300 342-1
- Safety EN60950
- GSM Network TBR 19, TBR 20

Notice: We have attempted to verify all information in this manual as of the publication date. Information in this manual may change without prior notice from RTD Finland Oy.

Published by:
Real Time Devices Finland Oy
Lepolantie 14
FIN-00660 Helsinki
Finland

Copyright 2001-2002 Real Time Devices Finland Oy
All rights reserved
Printed in Finland

PC/XT, PC/AT are registered trademarks of IBM Corporation.

PC/104 is a registered trademark of the PC/104 Consortium.

The Real Time Devices Logo is a registered trademark of Real Time Devices.

utilityModule is a trademark of Real Time Devices.

All other trademarks appearing in this document are the property of their respective owners.

Table of Contents

List of illustrations and tables	6
Chapter 1 Introduction	7
Features	7
GPRS GSM cellular modem.....	7
GPS receiver	8
16C550 compatible UARTs	8
I/O interfaces.....	8
Mechanical description.....	8
Connector description	9
What comes with your board?.....	9
Using this manual.....	9
When you need help	9
Chapter 2 Board settings	10
Factory configured jumper settings	11
Base address jumpers.....	12
Host interrupts.....	14
Chapter 3 Board installation	15
Board installation.....	15
General purpose digital I/O connector	16
SIM card holder	17
Chapter 4 Hardware description	19
The GPRS GSM wireless modem module.....	21
GSM antenna considerations	21
SIM card reader	22
GPS receiver	22
GPS antenna considerations.....	23
UART serial port circuitry	24
Digital I/O	24

Chapter 5 Board operation and programming..... 25

Defining the memory map	25
GSM BASE+400h Digital I/O	26
GSM BASE+402h status register	26
GSM BASE+403h control register	26
GPS BASE+400h Digital I/O	27
GPS BASE+401h status register	27
Starting up and logging into the GSM network.....	28
Interrupts	28

Chapter 6 COM17035 Specifications 34**Chapter 7 Return policy and warranty..... 36****List of illustrations and tables**

Fig. 2-1 COM17035 Board layout showing jumper locations

Fig. 2-2 Base address jumpers illustrating addresses 2E8h and 3E8h

Fig. 2-3 Interrupt jumpers from left to right: IRQ 2,5,6,7,10,11,12,15 and G

Fig. 3-1 COM17035 integrated in a RTD PC/104 cpuModule stack together with a HPWR104HR and a CMM series cpuModule

Fig. 3-2 Digital I/O connector layout of the COM17035

Fig. 3-3 External SIM card interface of the COM17035

Fig. 3-4 ESIM2035 External SIM card interface board

Fig. 4-1 Block diagram of the COM17035

Fig. 4-2 GPS antenna bias voltage selection

Table 2-1 Factory configured jumper settings

Table 2-2 Base address jumper settings COM17035

Table 3-1 Pin outs of the COM17035 digital I/O interface connector

Table 5-1a General I/O map of the COM17035 GSM UART

Table 5-1b General I/O map of the COM17035 GPS UART

Chapter 1 - INTRODUCTION

This user's manual describes the operation of the RTD COM17035 integrated global GPRS GSM wireless modem and GPS module designed for mobile, marine, and automotive applications.

Features

Some of the key features of the COM17035 include:

- Low power Siemens MC35 cellular engine, GPRS GSM900/1800Mhz
- 9,6/14,4 kbit/s datarate, group 3 faxes, SMS and SMS cell broadcast
- up to 50 kbit/s using GPRS data connection (may be limited by network)
- Onboard SIM-card socket for 3V standard cards
- 12-channel low power Fastrax iTrax02 GPS receiver
- NMEA and binary protocols
- +3,3V and +5V active GPS antenna support
- 16C550 UART interfaces to host computer
- Supports COM1, COM2, COM3, COM4 or COMx
- Available IRQ's 2,5,6,7,10,11,12,14,15
- Status LED's indicating GSM and GPS activity and status
- 16 TTL I/O's 8 outputs 8 inputs
- +5V only operation, 2.3W typical
- Wide operating temperature range -20 to + 70C guaranteed
- Onboard temperature sensor
- Fully PC/104 compliant, IDAN versions available

The following paragraphs briefly describe the major features of the COM17035. A more detailed discussion is included in Chapter 4 (Hardware description) The boards installation is described in Chapter 2 (Board Installation).

GSM cellular modem

The Real Time Devices COM17035 wireless GPRS GSM modem unit provides a direct and reliable GPRS connection to GPRS GSM 900MHz and 1800MHz mobile fields around the world. GPRS GSM connectivity is achieved using the Siemens MC35. This unit works in the 900/1800MHz band supporting GSM 02.22 network/service provider personalisation.

Connect any standard dual band GSM antenna directly to the OSX connector of the COM17035. The antenna should be connected to the MC35 using a flexible 50-Ohm cable. In IDAN installations the antenna connection is brought to the front side of the IDAN-frame. The antenna specifications: Frequency 890-910MHz (TX), 935-960MHz (RX); Impedance 50 Ohms; VSWR 1,7:1 (TX) 1,9:1 (RX); Gain <1,5dB references to 1/2-dipole; 1W power (cw) max 2W peak at 55 degrees Centigrade.

A SIM-card socket is located on the solder side of the module. The card can only be removed while the MC35 has been placed in shutdown mode. The COM17035 is also available using the TC35 GSM Modem. A TC35 based dual band GPS/GSM modem COM16035 is available now if only GSM data connectivity is required. During the 3Q 2002 RTD Finland will also release a triple band GPRS module that will operate in the 1900MHz band. The part number will be COM17045. Engineering samples will be available in August.

GPS receiver

Integrated on your COM17035 is a fast fix 12-channel low power iTrax02 GPS receiver from Fastrax. This new receiver will work reliably in a variety of installations. The receiver will work with either 3,3V or 5,0V active or with passive antennas. The power consumption of the GPS receiver is 125mW fully operational. A fast 1 to 4Hz updating rate is achieved using the binary iTalk protocol. Two output formats are available: the NMEA-0183 ASCII protocol or the iTalk proprietary binary protocol. Switching between these protocols is controlled with one bit in the internal board registers.

16C550 compatible UARTs

Communication to the COM17035 board is performed through two standard UART channels, one for the GSM and one for the GPS unit. These onboard serial ports leave the other system serial ports free for the user. All operating systems will recognize and support these 16C550 standard UARTs, and therefore no special communication drivers are needed to receive data from your COM17035 board. The address and interrupt of your serial channels can be individually set with the onboard jumper fields.

I/O interfaces

The COM17035 can be controlled and monitored from the software through two dedicated I/O registers. A special I/O connector is available for the user to connect to the general-purpose TTL level digital I/O.

Mechanical description

The COM17035 is designed on a PC/104 form factor. An easy mechanical interface to both PC/104 and RTD IDAN systems can be achieved. Stack

your COM17035 directly on a PC/104 compatible CPU module using the onboard mounting holes and standoffs.

Connector description

The GPS and GSM antenna interfaces use an OSX type miniature coaxial connector. Connect your antenna directly to the COM17035 antenna connectors, or use a short cable inside your enclosure to connect to a feed through connector to allow connection of the antennas to the wall of your enclosure. All I/O connections are made using header type terminals.

What comes with your board

Your COM17035 package contains the following items:

- COM17035 board
- User's manual

Note: Device drivers and example software available on our website

If any item is missing or damaged, please send an EMAIL to Real Time Devices Finland sales service department at Internet address: [<sales@rtdfinland.fi>](mailto:sales@rtdfinland.fi).

Note that RTD Finland also can offer a COM17035 starter kit that will include an active antenna with ready cables for direct evaluation and testing of this module. The part number for this starter kit is **SK-COM17035**.

Using this manual

This manual is intended to help you install your new COM17035 module and get it working quickly, while also providing enough detail about the board and it's functions so that you can enjoy maximum use of it's features even in the most demanding applications.

When you need help

This manual and all the example programs will provide you with enough information to fully utilize all the features on this board. If you have any problems installing or using this board, contact our Technical support department at [<techsupport@rtdfinland.fi>](mailto:techsupport@rtdfinland.fi). When sending us an Email request please include the following information: Your company's name and address, your name, your telephone number, and a brief description of the problem.

Chapter 2 - BOARD SETTINGS

The COM17035 board has jumper settings, which can be changed to suit your application and host computer configuration. The factory settings are listed and shown in the diagram at the beginning of this chapter. Make sure you completely study and understand this chapter before making changes to these settings.

Factory-Configured Jumper Settings

Table 2-1 below illustrates the factory jumper setting for the COM17035. Figure 2-1 shows the board layout of the COM17035 and the locations of the jumpers. The following paragraphs explain how to change the factory jumper settings to suit your specific application.

Table 2-1 Factory configured jumper settings (Please see figure 2-1 below for more detailed locations)

JUMPER NAME	DESCRIPTION	NUMBER OF JUMPERS	FACTORY SETTING
BASE	Base Addresses	6+6	2E8 / 6E8, 3E8 / 7E8
IRQ	Host interrupts	11+1, 11+1	5, 11G – jumper closed

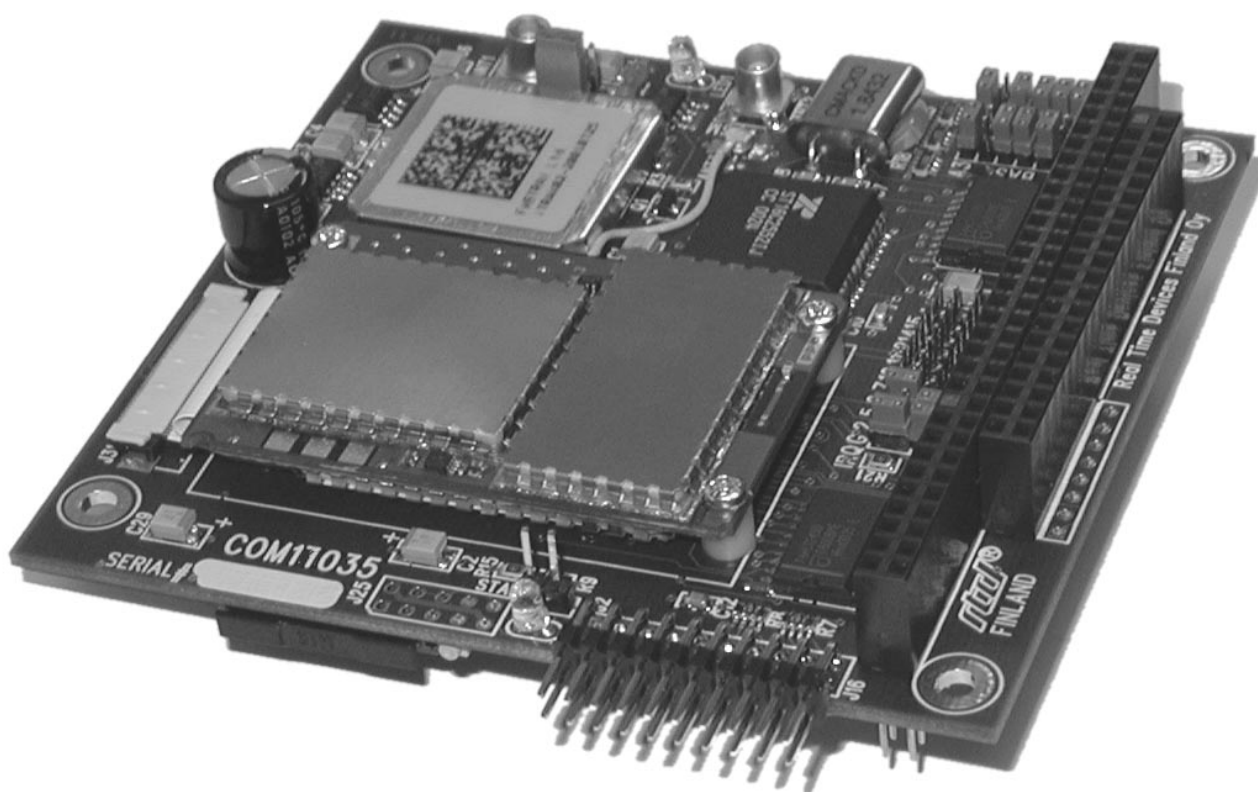

Fig. 2-1 COM17035 Board layout showing jumper locations

Base address jumpers (Factory setting: 2E8h / 6E8h, 3E8 /7E8)

The COM17035 is I/O mapped into the memory space of your host XT/AT. The board occupies two consecutive memory windows of 8 bytes starting from the base address for UART communication and 4 consecutive bytes starting from BASE+400h for the board control and status registers. As an example if your base address is set to be 2E8h for the serial port, the onboard control registers will start from 6E8h. Both devices, the GPS and the GSM modem, have independent settings for the base address and interrupt.

The most common cause of failure when you are first setting up your module is address contention: some of your computers I/O space is already occupied by other devices and memory resident programs. When the COM17035 attempts to use its own reserved memory addresses (which are being already used by another peripheral device) erratic performance can occur and the data read from the board may be corrupted.

To avoid this problem make sure you set up the base address by using the six jumpers on the right side of the board, this allows you to choose from a number of different addresses in your host computer's I/O map. Should the factory-installed settings be incompatible to your system configuration, you may change this setting to another using the options illustrated in Table 2-2 (overleaf). The table shows the jumper settings and their corresponding values in hexadecimal form. Ensure that you verify the correct location of the base address jumpers. When the jumper is removed it corresponds to a logical "0", connecting the jumper to a "1". When you set the base address of the module, record the setting inside the back cover of this manual.

COM17035 Base address configuration

BASE	A8	A7	A6	A5	A4	A3	BASE	A8	A7	A6	A5	A4	A3
200	0	0	0	0	0	0	300	1	0	0	0	0	0
208	0	0	0	0	0	1	308	1	0	0	0	0	1
210	0	0	0	0	1	0	310	1	0	0	0	1	0
218	0	0	0	0	1	1	318	1	0	0	0	1	1
220	0	0	0	1	0	0	320	1	0	0	1	0	0
228	0	0	0	1	0	1	328	1	0	0	1	0	1
230	0	0	0	1	1	0	330	1	0	0	1	1	0
238	0	0	0	1	1	1	338	1	0	0	1	1	1
240	0	0	1	0	0	0	340	1	0	1	0	0	0
248	0	0	1	0	0	1	348	1	0	1	0	0	1
250	0	0	1	0	1	0	350	1	0	1	0	1	0
258	0	0	1	0	1	1	358	1	0	1	0	1	1
260	0	0	1	1	0	0	360	1	0	1	1	0	0
268	0	0	1	1	0	1	368	1	0	1	1	0	1
270	0	0	1	1	1	0	370	1	0	1	1	1	0
278	0	0	1	1	1	1	378	1	0	1	1	1	1
280	0	1	0	0	0	0	380	1	1	0	0	0	0
288	0	1	0	0	0	1	388	1	1	0	0	0	1
290	0	1	0	0	1	0	390	1	1	0	0	1	0
298	0	1	0	0	1	1	398	1	1	0	0	1	1
2A0	0	1	0	1	0	0	3A0	1	1	0	1	0	0
2A8	0	1	0	1	0	1	3A8	1	1	0	1	0	1
2B0	0	1	0	1	1	0	3B0	1	1	0	1	1	0
2B8	0	1	0	1	1	1	3B8	1	1	0	1	1	1
2C0	0	1	1	0	0	0	3C0	1	1	1	0	0	0
2C8	0	1	1	0	0	1	3C8	1	1	1	0	0	1
2D0	0	1	1	0	1	0	3D0	1	1	1	0	1	0
2D8	0	1	1	0	1	1	3D8	1	1	1	0	1	1
2E0	0	1	1	1	0	0	3E0	1	1	1	1	0	0
2E8	0	1	1	1	0	1	3E8	1	1	1	1	0	1
2F0	0	1	1	1	1	0	3F0	1	1	1	1	1	0
2F8	0	1	1	1	1	1	3F8	1	1	1	1	1	1

0 = JUMPER OFF**1 = JUMPER CLOSED**

Table 2-2 Base address jumper settings for the COM17035, default jumper settings are highlighted.

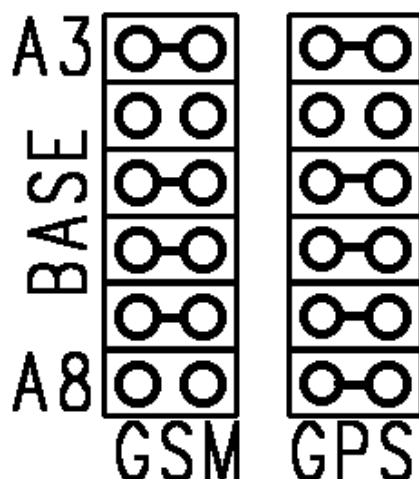

Fig. 2-2 Base address jumpers illustrating address 2E8 and 3E8h, A8 is to the bottom, A3 is located to the top of the jumper block

Host interrupts (Factory setting: IRQ5, 11, G closed)

The header connector, shown in Figure 2-3 below, lets you connect the onboard control logic interrupt outputs to one of the interrupt channels available on the host computer XT/AT bus.

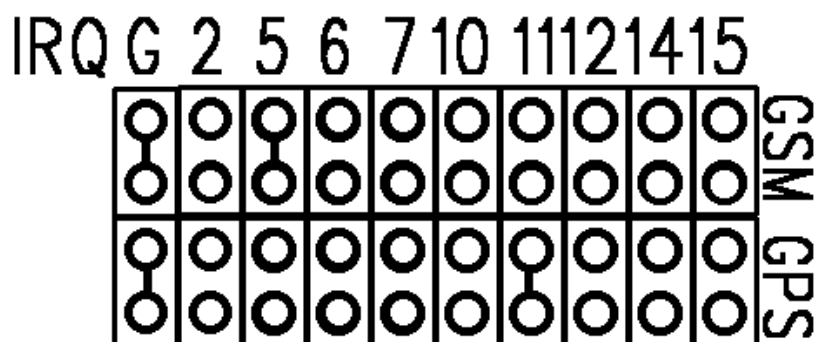

Fig. 2-3 Interrupt jumpers from left to right IRQ2,5,6,7,10,11,12,14,15 and G

Note: The COM17035 hardware supports interrupt sharing! Jumper G must be closed on one module per used interrupt. For example if two boards share interrupt number 7 only one board may have the G jumper closed. The G jumper connects a 1KOhm resistor to ground while the shared interrupts are 3-stated pulling the line to an inactive level.

Chapter 3 BOARD INSTALLATION

The COM17035 GSM modem module is designed to directly mount on top or under your RTD PC/104 cpuModule stack. This chapter tells you step-by-step how to install your COM17035 into your system.

Board installation

Keep your board in its antistatic bag until you are ready to install it to your system! When removing it from the bag, hold the board at the edges and do not touch the components or connectors. Please handle the board in an antistatic environment and use a **grounded** workbench for testing and handling of your hardware. Before installing the board in your computer, check the power cabling. Failure to do so may cause the power supply unit to malfunction or even cause permanent damage.

General installation guidelines:

- Touch the grounded metal housing of your computer to discharge any antistatic buildup and then remove the board from its antistatic bag.
- Hold the board by the edges and install it in an enclosure or place it on the table on an antistatic surface
- Install your board in your system, and wire the power supply correctly. Failure to do so may cause the power supply unit to malfunction or even cause permanent damage to the device.
- Check all wiring connections once and then once more again
- Connect the SIM card and the GSM and GPS antennae to the OSX connectors on the COM17035
- Apply power to your system

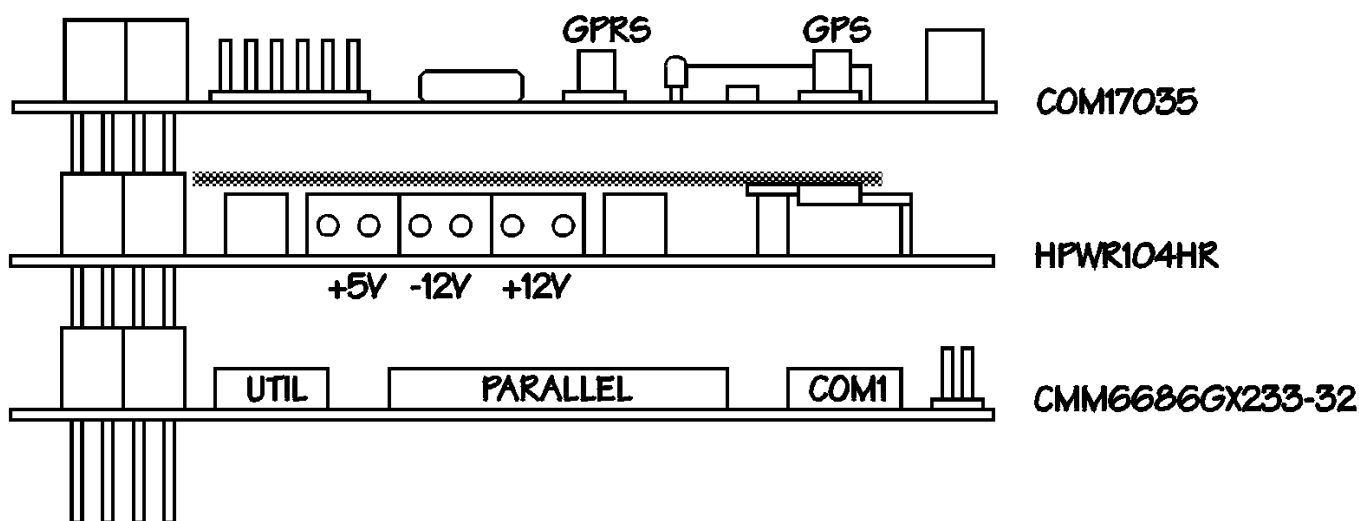

Fig. 3-1 COM17035 integrated in a RTD PC/104 cpuModule stack together with a HPWR104HR power supply module and a CMM series cpuModule

General purpose digital I/O connector

The Table 3-1 below shows the pin outs of the COM17035 digital I/O interface. The signals in this gender connector can be used as general purpose TTL level I/O lines to interface to LCD displays, LED's, bush buttons or relays. Note that Figure 3-2 shows two connectors together. The connector J28 carries all inputs and J3 carries all the outputs.

PIN J2	Description	PIN J2	Description
1	GND	2	Out0
3	Out1	4	Out2
5	Out3	6	Out4
7	Out5	8	Out6
9	Out7	10	+5V
PIN J16	Description	PIN J16	Description
1	GND	2	In0
3	In1	4	In2
5	In3	6	In4
7	In5	8	In6
9	In7	10	+5V

Table 3-1 Pin outs of the COM17035 digital I/O interface connector

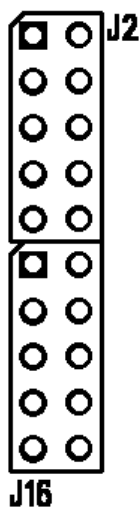

Fig 3-2 Digital I/O connector layout of the COM17035

SIM card holder

The figure 3-3 below shows the mechanical construction of the +3V standard SIM-card holder. In the figure the card is in the ejected state. Press the card carrier into the holder. To eject the SIM-card, press the yellow ejector button. The COM17035 also supports an external SIM card interface board the ESIM2035. This external card interface can be attached to the wall of your enclosure with a 150mm long cable. This is the maximum guaranteed length.

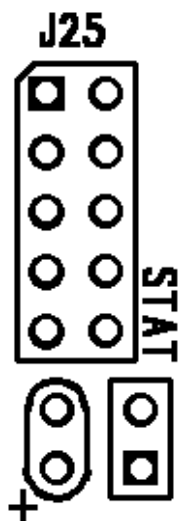

Fig 3-3 External SIM card interface of the COM17035-2.

Figure 3-4 below shows a picture of the external SIM card interface board.

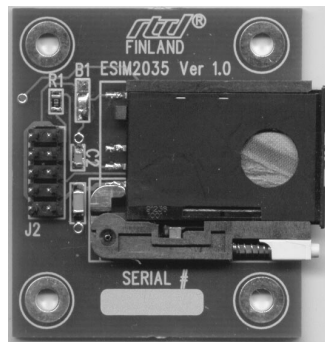

Figure 3-4 ESIM35 board

Note that the ESIM2035 is configured differently for the GSM20 and the COM17035. The units are not interchangeable. Once the MC35 GSM modem is able to initialise itself after power-up and correctly detect the SIM card the green status LED will be lit. If the LED is not illuminated you can not interface to your GSM modem. See Figure 3-3 for the location of the “STAT” LED. The header/mounting holes immediately next to the LED can be used to connect to an LED externally mounted to the enclosure wall for example. The “STAT” LED will not indicate detection of the GSM field or network access.

Chapter 4 - **HARDWARE DESCRIPTION**

This chapter describes the major hardware building blocks of the COM17035:

- The GPRS GSM wireless modem module
- GSM antenna considerations
- SIM card reader
- GPS receiver module
- GPS antenna considerations
- UART serial port circuitry
- Digital I/O

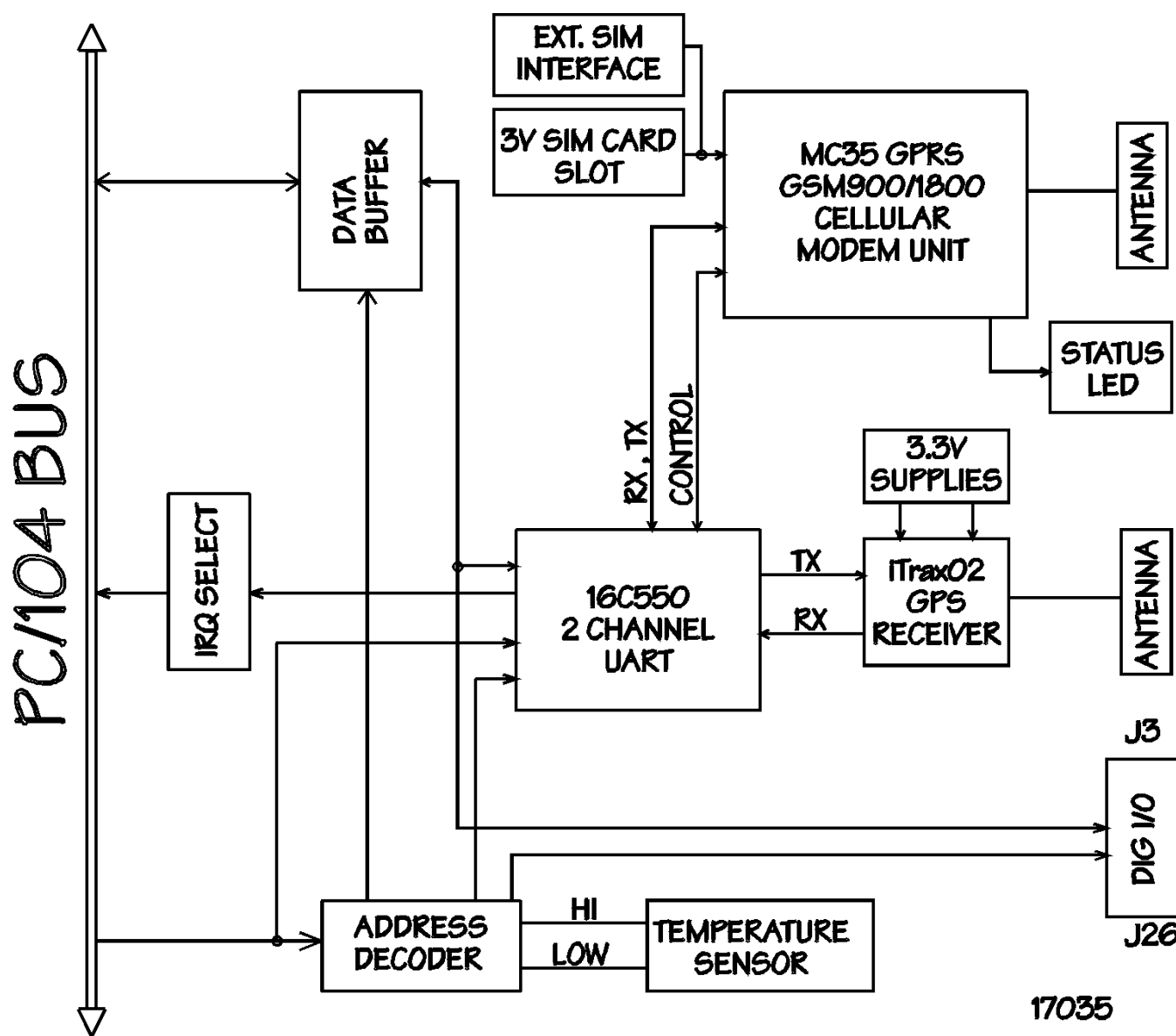

17035

Fig. 4-1 Block diagram of the COM17035

The GPRS GSM wireless modem module

The COM17035 wireless GPRS GSM modem is built around the Siemens MC35 dual band 900/1800MHz GPRS cellular engine. It is designed both for handling complex industrial applications such as telemetry, telematics or communication, and for integration in stationary or mobile fields all over the world. General information on these products is available at the following Internet addresses: http://www.siemens.de/gsm_e and <http://www.siemens.de/gsm> in german language.

The COM17035 is capable of powerful communication over a speed of 9,6 kbps or CSD up to 14,4 kbps (as of 06/2001) using GSM data interfacing. GPRS datarates can reach up to 50 kbit/s depending on the network capacity and the network load. In very loaded GSM networks GPRS data throughput may be at the level of 9600 baud. Engineers must take into account that GPRS datarates will vary dynamically depending on network conditions. This must be considered when designing software and system specifications. Roaming agreements and GPRS data support may not in all cases be available when moving from country to country. Check with your local network provider for GPRS coverage.

The COM17035 is capable of FAX and standard SMS text messages. The data terminal rate is 9600 baud for all host commands (AT commands). The COM17035 modem module antenna interface connector uses an OSX connector. The mating antenna connectors and cables are supplied from RTD Finland Oy. Temperature monitoring is possible using the onboard temperature sensor. Limit data can be interrogated from the COM17035 status register bits 2-3.

GSM Antenna considerations

The antenna used must meet the following specifications: Frequency 890-910 MHz (TX), 935-960MHz (RX); Impedance 50 Ohms; VSWR 1,7:1 (TX) 1,9:1 (RX); Gain <1,5dB references to 1/2-dipole; 1W power (cw) max 2W peak at 55 degrees Centigrade. Typically standard GSM antennas use a female FME connector. This connector needs an adapter unit before it can be connected to the COM17035.

RTD Finland Oy recommends the use of high quality antennas with the COM17035. We have tested successfully with antennas from Hirschmann Rheinmetall Elektronik.

Visit <http://www.hirschmann.de/> for information on GSM antennae.

A very useful AT command that shows quality of the signal reception is : AT+SCQ, the signal quality +CSQ: value (Value should be > 11) shows the quality of the network signal.

SIM-card reader

Standard 3V and dual voltage SIM-cards can be used with the COM17035. Older 5V SIM cards will not work, though they may operate in standard GSM cellular phones. These new 3V SIM cards are no older than two years. The SIM-card holder has a card detection circuit that will in theory allow hot insertion and removal of the card. This is **NOT** recommended, since the SIM card contents can become corrupted if it is removed while the MC35 GSM modem is writing to it.

A very useful AT command that shows detection of the SIM card is: **AT^SCID**. The SIM card identifier is given as a reply **^SCID: value** shows the ID of the SIM card. If no ID is detected the MC35 can not read the SIM card and can not connect to the GSM service provider network.

To add an entry to your SIM card you may use the AT+CPBW command. In this example we add the RTD Finland phone number +358 9 346 4538 to the SIM card memory location "1" with the following AT command set:

AT+CPBW=1,35893464538,145,RTDFinland

AT+CREG? Will indicate if the COM17035 is logged into the network. If the reply for example is **+CREG: 0,1** it means that connection to the home network is valid. A complete AT-instruction set documentation is included in the MC35 user's manual.

GPS receiver

Intergarated on the COM17035 is an iTrax02 low power fast-fix 12-channel GPS receiver from Fastrax. This GPS receiver is especially designed for portable and mobile applications. This version of the GPS does not support differential operation. RTD Finland can also provide solutions for indoor navigation using pseudolites (Pseudo Satellite) instead of satellites in the sky for positioning. In this case the standard GPS receiver can be substituted by a pseudolite receiver. Application areas include warehouse navigation.

The iTrax02 sensitivity provides continuous tracking and navigation down to a signal level of -145 dBm and a cold start TTFF of 50 seconds (no initialisation), 30 seconds for warm start (almanac) and one second for quick start. Even with this performance the power consumption is

approximately 100mW with a 1s update-rate. This figure does not include the active antenna power consumption. A complete GPS configuration program for the iTrax02 GPS Workbench is available from the manufacturer's website at <http://www.fastrax.fi/>. This program allows you to completely reconfigure the operation of the GPS receive. To use this program you must configure the GPS to operate in iTalk protocol using the RTD GPS diagnostics program.

GPS data is output only when the receiver has a fix. The COM17035 is configured to output NMEA-0183 Ver 3.0 data after reset and can be changed to binary protocol through a bit in the control register.

GPS Antenna considerations

GPS active antennas are mostly active today. The COM17035 accepts either +5V or +3,3V active GPS antennas. A three-terminal header is used to select the operating voltage of the antenna. The internal gain of the GPS receiver can be programmably adjusted to low-output signals or even to interface to passive antennas. This operation is normally not needed, but it can be done using the Fastrax GPS Workbench program.

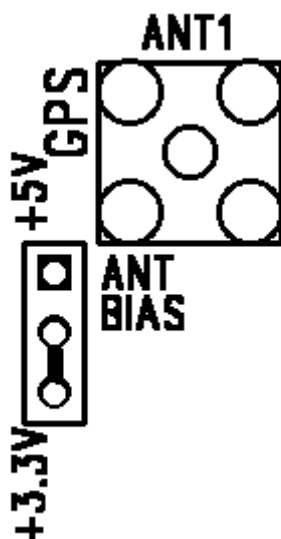

Fig. 4-2 GPS antenna bias voltage

A 90 degree 50 Ohm OSX connector should be selected to directly plug into the antenna connector on the board. High quality low loss antenna cable should be used. Try to reduce the number of connectors on the cable to minimise signal reflections. Signal reflections on the antenna line may cause incorrect readings for altitude information.

UART serial port circuitry

GPRS GSM and GPS data are sent and received through two standard 16C550 compatible UARTs. All today's operating systems will recognize and support this serial communication device. The COM17035 uses its own onboard serial port and will not reserve serial port resources from the system. The I/O base addresses and interrupts for these serial ports can be flexibly set as has been described in previous chapters of this manual. This user's manual will not wade into details of serial port programming. This information is commonly available today. You can use any communication software package or terminal program to connect to your COM17035 UART. Just make sure you set up the I/O and IRQ right. The correct terminal speed for AT commands is 9600 baud, 8 databits, no parity, one stopbit, and hardware handshake. The UART on the board is specified for full operation from -40 to +85C. The oscillator frequency is set to be 1.8432MHz. Note that the UART interrupt can be disabled or enabled from software by writing to bit 01 in address BASE+0x402.

The GPS receiver has two available protocols. You may select to use either the NMEA protocol or alternatively the iTalk binary protocol. The GPS receiver has two internal serial ports that operate in parallel. These outputs are multiplexed into one 16C550 UART channel on the COM17035 board. You may change between protocols by writing to a control bit in the internal registers of the board. This will be described in the later chapters of this manual.

Digital I/O

For general-purpose digital I/O interfacing a 16-bit digital I/O port is provided. This port includes 8 TTL-level digital outputs that are cleared (to 0) after system reset. Also are included 8 digital inputs with 10K Ohm pull-down resistors. These I/O's are located on the left side of the board. These I/O's are ideal to be used to interface to LCD displays, LED's pushbuttons or other low power controls.

Chapter 5 BOARD OPERATION AND PROGRAMMING

This chapter shows you how to program and use your COM17035. It provides a general description of the I/O map. Detailed serial port programming tips are not within the scope of this manual.

Defining the Memory Map

The memory map of the COM17035 occupies two groups of eight bytes of host PC I/O space. This window is freely selectable by the user as described in *Chapter 2, Table 2-2*. After setting the base address you have access to the internal resources of the COM17035 control logic. These resources are not described in detail, since they are mapped as a standard PC serial port. For more details on the EXAR ST16C550IJ44 UART chip programming please download the component specific data t from the website: <http://www.exar.com/products/st16c550.html>

ADDR (hex)	REGISTER	DIR	COMMENTS
BASE	TXD	O	Only if control reg. Bit 7=0
	RXD	I	Only if control reg. Bit 7=0
	BAUD div. Low		Only if control reg. Bit 7=1
BASE+1	BAUD div. High		Only if control reg. Bit 7=1
	IRQ enable		Only if control reg. Bit 7=0
BASE+2	IRQ ID		
BASE+3	Line control		
BASE+4	Modem control		
BASE+5	Line status		
BASE+6	Modem status		
BASE+400	Digital I/O	I/O	Digital I/O port
BASE+402	GSM status	I/O	Configuration registers
BASE+403	GSM control	I/O	Power control

Table 5-1a General I/O map of the COM17035 GSM UART

BASE+400 Digital I/O (R/W)

This address is used to interface to the digital I/O port of the COM17035, writing to this address will transfer the data out of the output port, while reading from this address will return the data from the digital inputs.

BASE+402 GSM Status (R/W, 0x00 after reset)**Write**

Bit 0	RESERVED	
Bit 1	/EN_INT	0 – UART interrupt enabled; 1 - disabled
Bit 2	RESERVED	
Bit 3	RESERVED	

Read

Bit 0	/EN_RST	state
Bit 1	/EN_INT	state
Bit 2	TEMP_LOW	1 - Board temperature below –20C
Bit 3	TEMP_HIGH	1 - Board temperature over +70C

BASE+403 GSM Control (R/W, 0x00 after reset)**Write**

Bit 0	Ignition signal	1 – > 0 – results in IGN signal
Bit 1	Powerdown of the MC35	1 – Power down; 0 – Power on
Bit 2	RESERVED	
Bit 3	RESERVED	

Read

Bit 0	Ignition signal	state
Bit 1	Powerdown of the MC35	state
Bit 2	RESERVED	
Bit 3	RESERVED	

ADDR (hex)	REGISTER	DIR	COMMENTS
BASE	TXD	O	Only if control reg. Bit 7=0
	RXD	I	Only if control reg. Bit 7=0
	BAUD div. Low		Only if control reg. Bit 7=1
BASE+1	BAUD div. High		Only if control reg. Bit 7=1
	IRQ enable		Only if control reg. Bit 7=0
BASE+2	IRQ ID		
BASE+3	Line control		
BASE+4	Modem control		
BASE+5	Line status		
BASE+6	Modem status		
BASE+400	Digital I/O	I/O	Digital I/O port
BASE+401	GPS status	I/O	Configuration registers
RESERVED			

Table 5-1b General I/O map of the COM17035 GPS UART

BASE+400 Digital I/O (R/W)

This address is used to interface to the digital I/O port of the COM17035, writing to this address will transfer the data out of the output port, while reading from this address will return the data from the digital inputs.

BASE+401 GPS Status (R/W, 0x00 after reset)**Write**

Bit 0	CH_SEL	0 – NMEA mode; 1 – iTalk protocol
Bit 1	GPS_RESET	1 – Hard reset of GPS receiver, 0 – active
Bit 2	RESERVED	
Bit 3	/EN_INT	0 – GPS interrupt enabled; 1 – disabled

Read

Bit 0	CH_SEL	state
Bit 1	GPS_RESET	state
Bit 2	GPIO8 of GPS	state (Reserved for future use and testing)
Bit 3	/EN_INT	state

Starting up and logging into the GSM network

With no power applied insert your +3V or dual voltage SIM into the card-holder on the solder side of the board. Connect the antenna cable to the MC35 antenna connector and power up your PC/104 system. The COM17035 will initialise with the system. After this the status LED will blink for a while until the MC35 is logged into the network. If you have the PIN code enabled, the COM17035 status LED will continue to blink until the PIN code is given through the terminal mode with AT command **AT+CPIN"XXXX"**, unless **AT^SFLC** (facility lock for PIN code) has been set. Once the COM17035 is logged onto the network the LED will be lit continuously.

INTERRUPTS

What is an interrupt?

An interrupt is an event that causes the processor in your computer to temporarily halt its current process and execute another routine. Upon completion of the new routine, control is returned to the original routine at the point where its execution was interrupted.

Interrupts are a very flexible way of dealing with asynchronous events. Keyboard activity is a good example; your computer cannot predict when you might press a key and it would be a waste of processor time to do nothing whilst waiting for a keystroke to occur. Thus the interrupt scheme is used and the processor proceeds with other tasks. When a keystroke finally occurs, the keyboard then 'interrupts' the processor so that it can get the keyboard data. It then places it into the memory, and then returns to what it was doing before the interrupt occurred. Other common devices that use interrupts are A/D boards, network boards, other used serial ports etc.

Interrupt request lines

To allow different peripheral devices to generate interrupts on the same computer, the PC AT bus has interrupt request channels (IRQ's). A rising edge transition on one of these lines will be latched into the interrupt controller. The interrupt controller checks to see if the interrupts are to be acknowledged from that IRQ and, if another interrupt is being processed, it decides if the new request should supercede the one in progress or if it has to wait until the one in progress has been completed. The priority level of the interrupt is determined by the number of the IRQ as follows; IRQ0 has the highest priority whilst IRQ15 has the lowest. Many of the

IRQ's are already used by the standard system resources, IRQ0 is dedicated to the internal timer, IRQ1 is dedicated to the keyboard input, IRQ3 for the serial port COM2, and IRQ4 for the serial port COM1. Often interrupts 2,5,7,10,11 and 15 are free for the user.

8259 Programmable Interrupt Controller

The chip responsible for handling interrupt requests in a PC is the 8259 Interrupt Controller. To use interrupts you will need to know how to read and set the 8259's internal interrupt mask register (IMR) and how to send the end-of-interrupt (EOI) command to acknowledge the 8259 interrupt controller.

Interrupt Mask Register (IMR)

Each bit in the interrupt mask register (IMR) contains the mask status of the interrupt line. If a bit is set (equal to 1), then the corresponding IRQ is masked, and it will not generate an interrupt. If a bit is cleared (equal to 0), then the corresponding IRQ is not masked, and it can then generate an interrupt. The interrupt mask register is programmed through **port 21h**.

End-of-Interrupt (EOI) Command

After an interrupt service routine is complete, the 8259 Interrupt Controller must be acknowledged by writing the value 20h to port 20h.

What exactly happens when an interrupt occurs?

Understanding the sequence of events when an interrupt is triggered is necessary to correctly write interrupt handlers. When an interrupt request line is driven high by a peripheral device (such as the COM17035), the interrupt controller checks to see if interrupts are enabled for that IRQ. It then checks to see if other interrupts are active or requested and determines which interrupt has priority. The interrupt controller then interrupts the processor. The current code segment (CS), instruction pointer (IP), and flags are pushed onto the system stack, and a new set of CS and IP are loaded from the lowest 1024 bytes of memory.

This table is referred to as the interrupt vector table and each entry to this table is called an interrupt vector. Once the new CS and IP are loaded from the interrupt vector table, the processor starts to execute code from the new Code Segment (CS) and from the new Instruction Pointer (IP). When the interrupt routine is completed, the old CS and IP are popped from the system stack and the program execution continues from the point where interruption occurred.

Using Interrupts in your Program

Adding interrupt support to your program is not as difficult as it may seem especially when programming under DOS. The following discussion will cover programming under DOS. Note that even the smallest mistake in your interrupt program may cause the computer to hang up and will only restart after a reboot. This can be frustrating and time-consuming.

Writing an Interrupt Service Routine (ISR)

The first step in adding interrupts to your software is to write an interrupt service routine (ISR). This is the routine that will be executed automatically each time an interrupt request occurs for the specified IRQ. An ISR is different from other sub-routines or procedures. First on entrance the processor registers must be pushed onto the stack before anything else! Second, just before exiting the routine, you must clear the interrupt on the COM17035 by writing to the Status register, and write the EOI command to the interrupt controller. Finally, when exiting the interrupt routine the processor registers must be popped from the system stack and you must execute the IRET assembly instruction. This instruction pops the CS, IP and processor flags from the system stack. These were pushed onto the stack when entering the ISR.

Most compilers allow you to identify a function as an interrupt type and will automatically add these instructions to your ISR with one exception: most compilers do not automatically add the EOI command to the function, you must do it yourself. Other than this and a few exceptions discussed below, you can write your ISR as any code routine. It can call other functions and procedures in your program and it can access global data. If you are writing your first ISR, we recommend you stick to the basics; just something that enables you to verify you have entered the ISR and executed it successfully. For example: set a flag in your ISR and in your main program check for the flag.

Note: If you choose to write your ISR in in-line Assembly, you must push and pop registers correctly and exit the routine with the IRET instruction instead of the RET instruction.

There are a few precautions you must consider when writing ISR's. The most important is, **do not use any DOS functions or functions that call DOS functions from an interrupt routine.** DOS is not re-entrant; that is, a DOS function cannot call itself. In typical programming, this will not happen because of the way DOS is written. But what about using interrupts? Consider then the following situation in your program: If DOS function X is

being executed when an interrupt occurs and the interrupt routine makes a call to the same DOS function X, then function X is essentially being called while active. Such cases will cause the computer to crash. DOS does not support such operations. The general rule is that do not call any functions that use the screen, read keyboard input or any file I/O routines, these should not be used in ISR's.

The same problem of re-entrancy also exists for many floating-point emulators. This effectively means that you should also avoid floating point mathematical operations in your ISR.

Note that the problem of reentrancy exists, no matter what programming language you use. Even, if you are writing your ISR in Assembly language, DOS and many floating point emulators are not re-entrant. Of course there are ways to avoid this problem, such as those which activate when your ISR is called. Such solutions are, however, beyond the scope of this manual.

The second major concern when writing ISR's is to make them as short as possible in term of execution time. Spending long times in interrupt service routines may mean that other important interrupts are not serviced. Also, if you spend too long in your ISR, it may be called again before you have exited. This will lead to your computer hanging up and will require a reboot.

Your ISR should have the following structure:

- Push any processor registers used in your ISR.
- Put the body of your routine here
- Clear the interrupt bit by reading COM17035 RXD register
- Issue the EOI command to the 8259 by writing 20h to 20h
- Pop all registers. Most C compilers do this automatically

The following C example shows what the shell of your ISR should be like:

```

/*-----
Function:  new_IRQ_handler
Inputs:   Nothing
Returns:  Nothing
-----*/
void interrupt far new_IRQ_handler(void)
{
    IRQ_flag = 1;    // Indicate to process interrupt has occurred

    {
        // Your program code to read UART
        // read to a data buffer for example:
        Guc_buffer[Gi_bufpos++] = inp(gi_SERIAL_DATA);
    }
    outp(0x20, 0x20); // Acknowledge the interrupt controller
}

```

Saving the Startup Interrupt Mask Register (IMR) and interrupt vector

The next step after writing the ISR is to save the startup-state of the interrupt mask register, (IMR) and the original interrupt vector you are using. The IMR is located in address 21h. The interrupt vector you will be using is located in the interrupt vector table which is an array of pointers (addresses) and it is located in the first 1024 bytes of the memory (Segment 0 offset 0). You can read this value directly, but it is better practice to use DOS function 35h (get interrupt vector) to do this. Most C compilers have a special function available for doing this. The vectors for the hardware interrupts on the XT - bus are vectors 8-15, where IRQ0 uses vector 8 and IRQ7 uses vector 15. Thus if your COM17035 is using IRQ5 it corresponds to vector number 13.

Before you install your ISR, temporarily mask out the IRQ you will be using. This prevents the IRQ from requesting an interrupt while you are installing and initializing your ISR. To mask the IRQ, read the current IMR at I/O port 21h, and set the bit that corresponds to the IRQ. The IMR is arranged so that bit 0 is for IRQ0 and bit 7 is for IRQ7. See the paragraph entitled *Interrupt Mask Register (IMR)* earlier in this discussion for help in determining your IRQ's bit. After setting the bit, write the new value to I/O port 21h.

With the startup IMR saved and the interrupts temporarily disabled, you can assign the interrupt vector to point to your ISR. Again you can overwrite the appropriate entry in the vector table with a direct memory write, but this is not recommended. Instead use the DOS function 25h (Set Interrupt Vector) or, if your compiler provides it, the library routine for setting up interrupt vectors. Remember that interrupt vector 8 corresponds to IRQ0, vector 9 for IRQ1 etc.

If you need to program the source of your interrupts, do that next. For example, if you are using transmitted or received messages as an interrupt source program it to do that. Finally, clear the mask bit for your IRQ in the IMR. This will enable your IRQ.

Common Interrupt mistakes

Remember hardware interrupts are from 8-15, XT IRQ's are numbered 0-7. Do not forget to clear the IRQ mask bit in the IMR. Forgetting to send the EOI command after ISR code. Disables further interrupts.

Example on Interrupt vector table setup in C-code:

```

void far _interrupt new_IRQ1_handler(void );           /* ISR function */
#define IRQ1_VECTOR 3                                /* Name for IRQ */
void (interrupt far *old_IRQ1_dispatcher)
    (es,ds,di,si,bp,sp,bx,dx,cx,ax,ip,cs,flags);     /* Variable to store
old IRQ_Vector */
void far _interrupt new_IRQ1_handler(void );

```

```

/*-----
Function:  init_irq_handlers
Inputs:    Nothing
Returns:   Nothing
Purpose:   Set the pointers in the interrupt table to point to
           our funtions ie. setup for ISR's.
-----*/

```

```

void init_irq_handlers(void)
{
    _disable();
    old_IRQ1_handler = _dos_getvect(IRQ1_VECTOR + 8);
    _dos_setvect(IRQ1_VECTOR + 8, new_IRQ1_handler);
    Gi_old_mask = inp(0x21);
    outp(0x21,Gi_old_mask & ~(1 << IRQ1_VECTOR));
    _enable();
}

```

```

/*-----
Function:  restore, do this before exiting program
Inputs:    Nothing
Returns:   Nothing
Purpose:   Restore the interrupt vector table.
-----*/

```

```

void restore(void)
{
    /* Restore the old vectors */
    _disable();

    _dos_setvect(IRQ1_VECTOR + 8, old_IRQ1_handler);
    outp(0x21,Gi_old_mask);

    _enable();
}

```

Chapter 6 - COM17035 SPECIFICATIONS

Host interface

16-bit PC/104 bus, XT-bus used for data

GSM modem specifications

Operational

GSM compatibility	EGSM900 and GSM1800 phase 2/2+
Datarate	9600 baud, 14400 baud CSD
	Up to 50 kbit/s with GPRS connection
Services supported	GSM data transmission, SMS, Fax group 3
Network personalisation	GSM 02.22
Status indicator	1 LED
Output power	Class 4 (4W) EGSM900 Class 1 (1W) GSM1800

SIM card reader

Voltage	3V or dual voltage cards
Compatibility	GSM11.11 and 11.12
Detection	SIM card detection supported

Antenna Interface

Impedance	50 Ohms
VSWR	TX: max 1.7:1 installed RX: max 1.9:1 installed
Gain	> 1.5dB, referenced to 1/2L dipole
3dB width of cone	vertical 80 deg, horizontal 360 deg
Maximum power	1W (cw), 2 W peak at +55C ambient
Connector	OSX

GPS specifications

General

L1 frequency, C/A code (SPS)	
12 independent tracking channels	
Separate search and acquisition engines	
Update rate	1fix/s or configurable
Accuracy	Position 10m CEP (50%) 0.2 m/s (50%)
Sensitivity	-145dBm
Status indicator	1 LED

Antenna Interface

External	Passive or active +3,3V or +5,0V BIAS
Connector	OSX, PCB mount

UART and I/O

UART compatibility	2 channels 16C550
Oscillator frequency	1.8432MHz
Connection	Full hardware handshaking supported
Base addresses	32+4
Interrupts	2,5,7,10,11,12,14 and 15
Digital I/O	8 TTL outputs, 8 TTL inputs w. 10K pull-down

COM17035 Electromechanical

Operating temperature range	-20 to +70 C, for the GSM operation -40 to +85C, for the GPS receiver
Humidity	RH up to 95% non condensing
Altitude	-1000 to 60.000 ft
Vibration	Survival 10G peak
Power consumption	2,3W min

Chapter 7 - RETURN POLICY AND WARRANTY

Return Policy

If the module requires repair, you may return it to us by following the procedure listed below:

Caution: Failure to follow this return procedure will *almost always* delay repair! Please help us expedite your repair by following this procedure.

- 1) Read the limited warranty, which follows.
- 2) Contact the factory and request a Returned Merchandise Authorization (RMA) number.
- 3) On a sheet of paper, write the name, phone number, and fax number of a technically competent person who can answer questions about the problem.
- 4) On the paper, write a detailed description of the problem with the product. Answer the following questions:
 - Did the product ever work in your application?
 - What other devices were connected to the product?
 - How was power supplied to the product?
 - What features did and did not work?
 - What was being done when the product failed?
 - What were environmental conditions when the product failed?
- 5) Indicate the method we should use to ship the product back to you.
 - We will return warranty repairs by UPS Ground at our expense.
 - Warranty repairs may be returned by a faster service at your expense.
 - Non-warranty repairs will be returned by UPS Ground or the method you select, and will be billed to you.
- 6) Clearly specify the address to which we should return the product when repaired.
- 7) Enclose the paper with the product being returned.
- 8) Carefully package the product to be returned *using anti-static packaging!* We will not be responsible for products damaged in transit for repair.
- 7) Write the RMA number on the outside of the package.
- 8) Ship the package to:

Real Time Devices Finland Oy

Lepolantie 14

FIN-00660 Helsinki

FINLAND

Limited Warranty

Real Time Devices, Inc. warrants the hardware and software products it manufactures and produces to be free from defects in materials and workmanship for one year following the date of shipment from REAL TIME DEVICES. This warranty is limited to the original purchaser of product and is not transferable.

During the one year warranty period, REAL TIME DEVICES will repair or replace, at its option, any defective products or parts at no additional charge, provided that the product is returned, shipping prepaid, to REAL TIME DEVICES. All replaced parts and products become the property of REAL TIME DEVICES. Before returning any product for repair, customers are required to contact the factory for an RMA number.

THIS LIMITED WARRANTY DOES NOT EXTEND TO ANY PRODUCTS WHICH HAVE BEEN DAMAGED AS A RESULT OF ACCIDENT, MISUSE, ABUSE (such as: use of incorrect input voltages, improper or insufficient ventilation, failure to follow the operating instructions that are provided by REAL TIME DEVICES, "acts of God" or other contingencies beyond the control of REAL TIME DEVICES), OR AS A RESULT OF SERVICE OR MODIFICATION BY ANYONE OTHER THAN REAL TIME DEVICES. EXCEPT AS EXPRESSLY SET FORTH ABOVE, NO OTHER WARRANTIES ARE EXPRESSED OR IMPLIED, INCLUDING, BUT NOT LIMITED TO, ANY IMPLIED WARRANTIES OF MERCHANTABILITY AND FITNESS FOR A PARTICULAR PURPOSE, AND REAL TIME DEVICES EXPRESSLY DISCLAIMS ALL WARRANTIES NOT STATED HEREIN. ALL IMPLIED WARRANTIES, INCLUDING IMPLIED WARRANTIES FOR MERCHANTABILITY AND FITNESS FOR A PARTICULAR PURPOSE, ARE LIMITED TO THE DURATION OF THIS WARRANTY. IN THE EVENT THE PRODUCT IS NOT FREE FROM DEFECTS AS WARRANTED ABOVE, THE PURCHASER'S SOLE REMEDY SHALL BE REPAIR OR REPLACEMENT AS PROVIDED ABOVE. UNDER NO CIRCUMSTANCES WILL REAL TIME DEVICES BE LIABLE TO THE PURCHASER OR ANY USER FOR ANY DAMAGES, INCLUDING ANY INCIDENTAL OR CONSEQUENTIAL DAMAGES, EXPENSES, LOST PROFITS, LOST SAVINGS, OR OTHER DAMAGES ARISING OUT OF THE USE OR INABILITY TO USE THE PRODUCT.

SOME STATES DO NOT ALLOW THE EXCLUSION OR LIMITATION OF INCIDENTAL OR CONSEQUENTIAL DAMAGES FOR CONSUMER PRODUCTS, AND SOME STATES DO NOT ALLOW LIMITATIONS ON HOW LONG AN IMPLIED WARRANTY LASTS, SO THE ABOVE LIMITATIONS OR EXCLUSIONS MAY NOT APPLY TO YOU.

THIS WARRANTY GIVES YOU SPECIFIC LEGAL RIGHTS, AND YOU MAY ALSO HAVE OTHER RIGHTS, WHICH VARY FROM STATE TO STATE.